

**AL 3580**  
con terminali

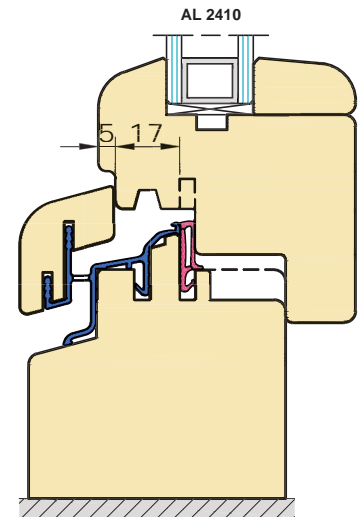

**AL 2410**  
con terminali

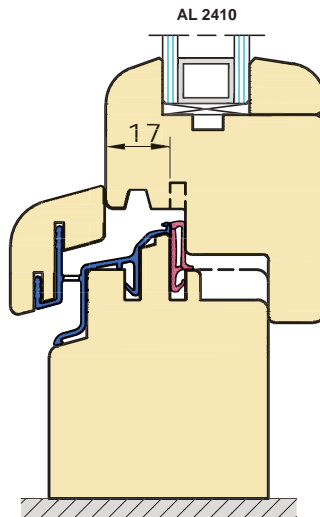
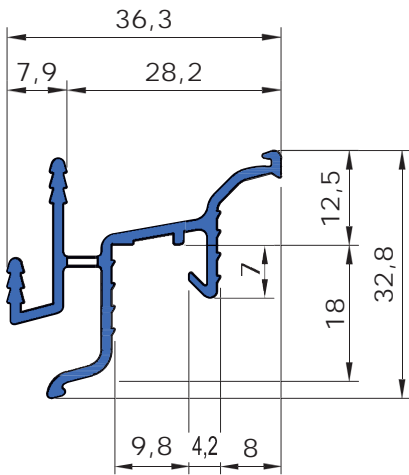
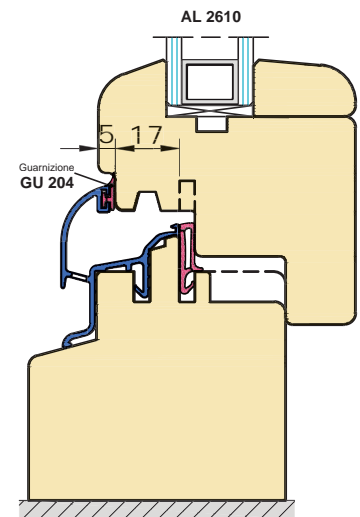
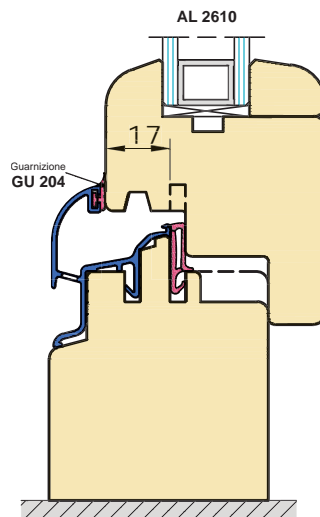
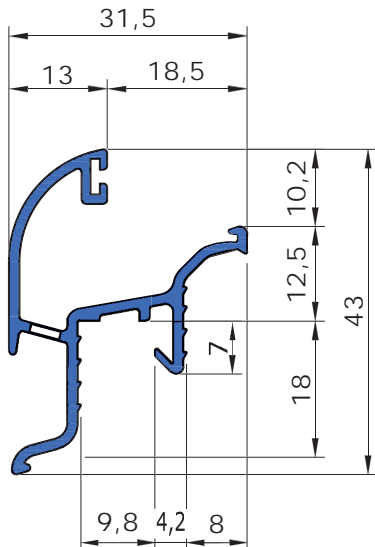

**AL 2610**  
con terminali

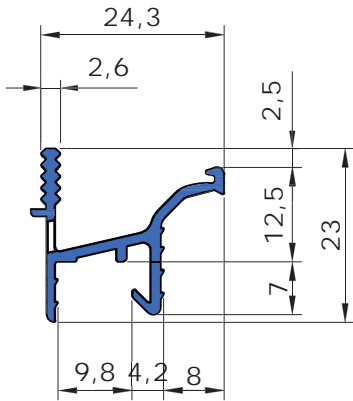

**AL 3270**  
con terminali

LOTTO MINIMO 2150 m

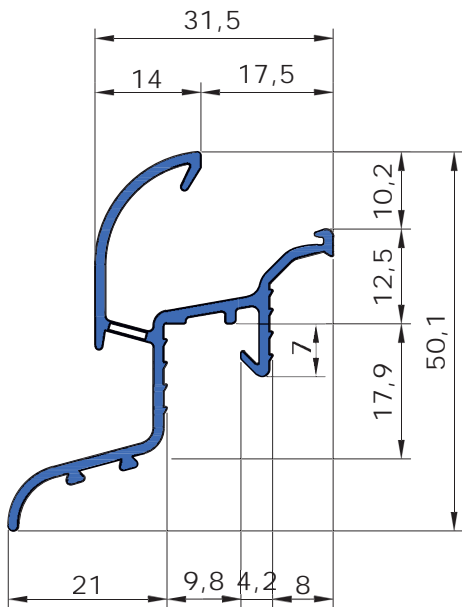
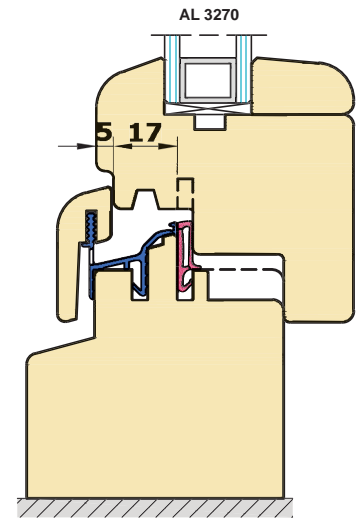
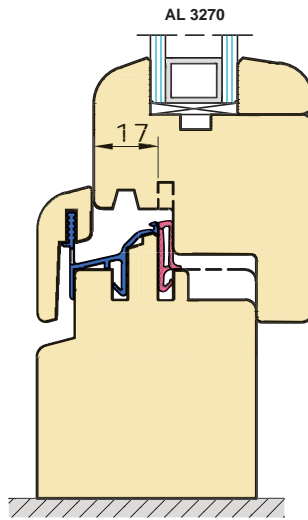

**AL 2630**  
con terminali

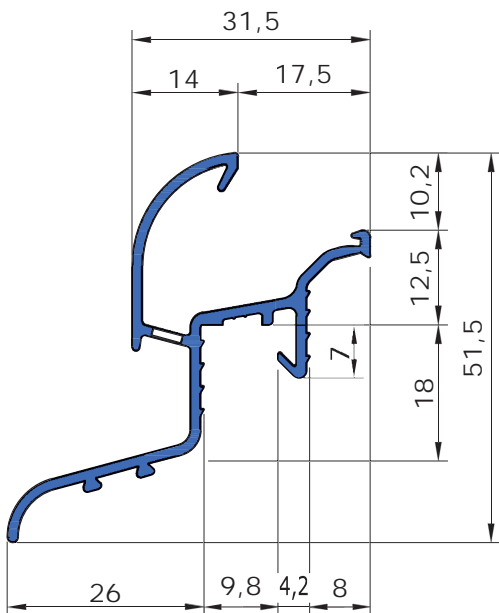
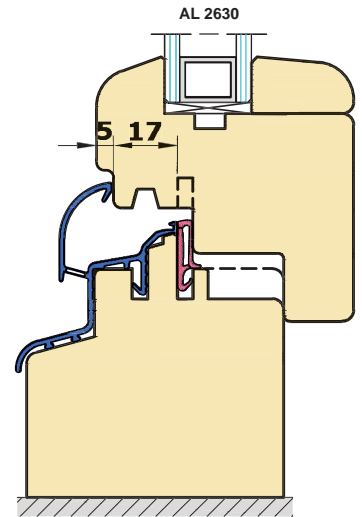
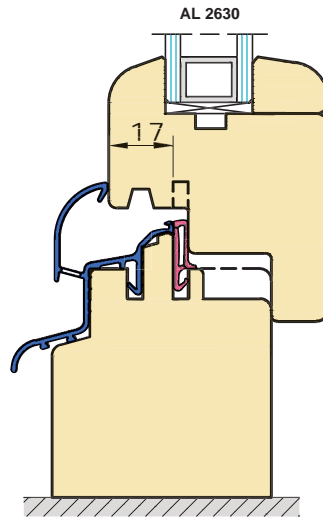

**AL 2640**  
con terminali

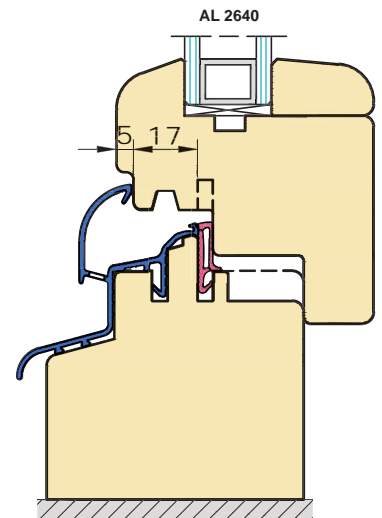
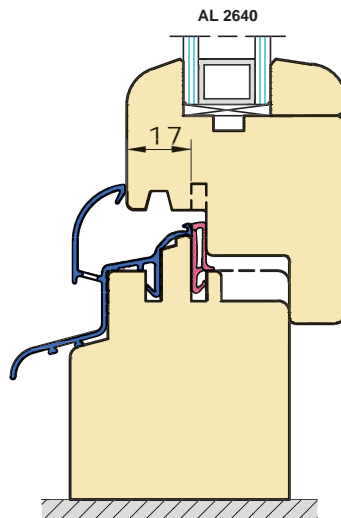

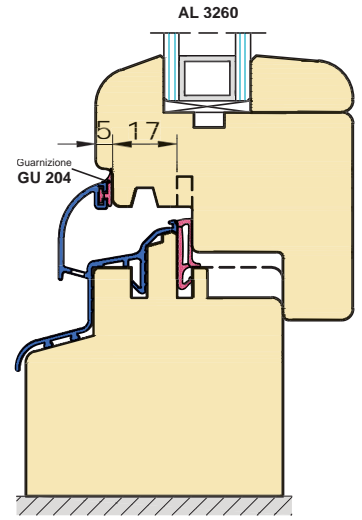
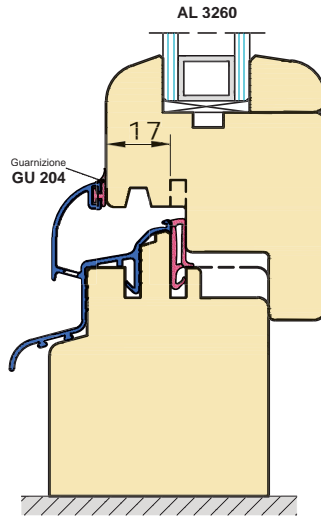
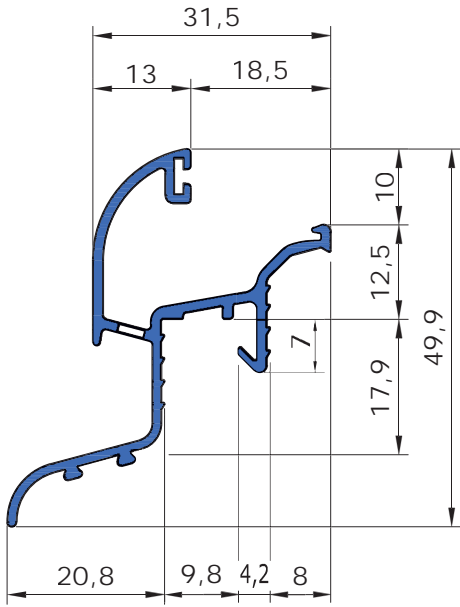

**AL 3260**  
con terminali

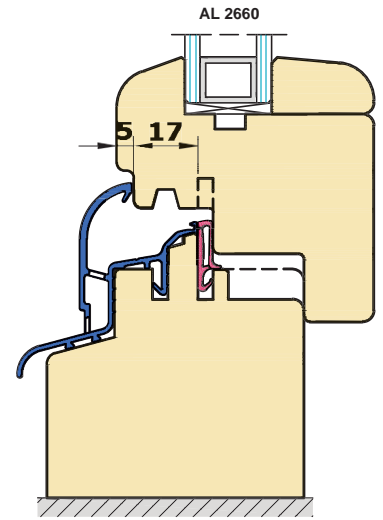
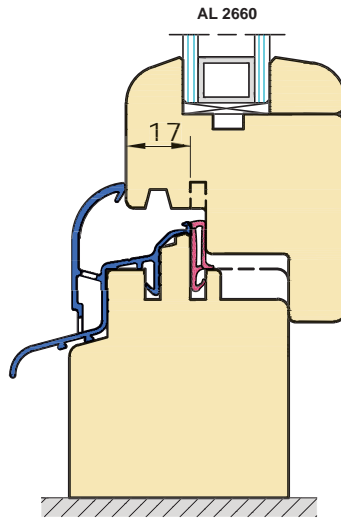
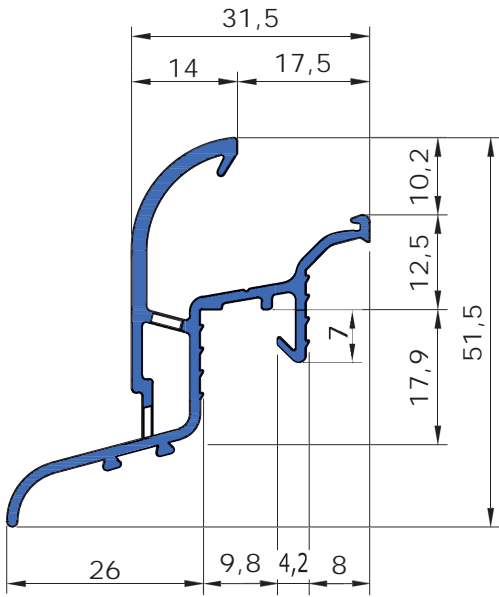

**AL 2660**  
con terminali

LOTTO MINIMO 900 m

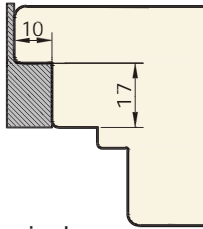

AL 2610  
AL 3270  
AL 3580

Terminale  
**T ...5.17.10**

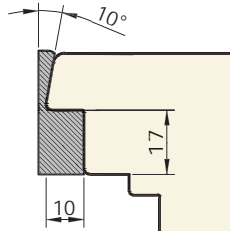

AL 2610  
AL 3580

Terminale  
**T ...7.17.10**

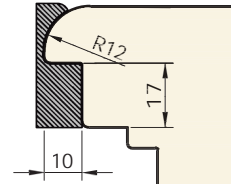

AL 2610  
AL 3580

Terminale  
**T ...9.17.10**

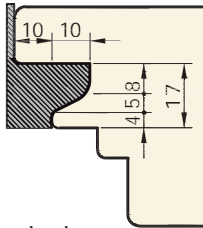

AL 2610  
AL 3270  
AL 3580

Terminale  
**T ...5.17G10**

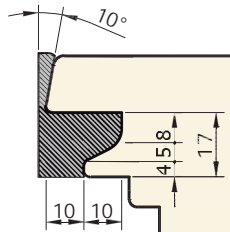

AL 2610  
AL 3580

Terminale  
**T ...7.17G10**

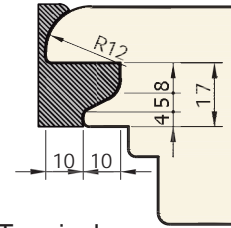

AL 2610  
AL 3580

Terminale  
**T ...9.17G10**

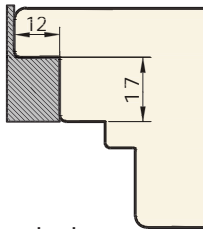

AL 2410  
AL 2610  
AL 2630  
AL 2640  
AL 2660  
AL 3260  
AL 3270  
AL 3580

Terminale  
**T ...5.17.12**

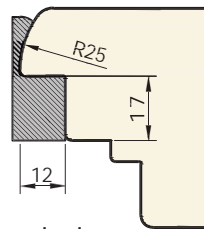

AL 2610  
AL 2630  
AL 2640  
AL 2660  
AL 3260  
AL 3580

Terminale  
**T ...9.17.12**

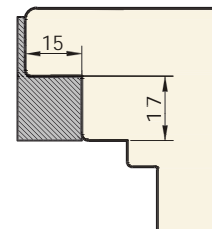

AL 2410  
AL 2610  
AL 2630  
AL 2640  
AL 2660  
AL 3260  
AL 3270  
AL 3580

Terminale  
**T ...5.17.15**

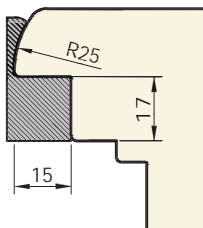

AL 2610  
AL 2630  
AL 2640  
AL 2660  
AL 3260  
AL 3580

Terminale  
**T ...9.17.15**

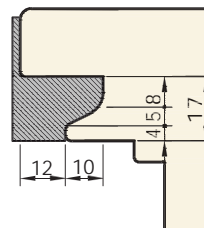

AL 2410  
AL 2610  
AL 2630  
AL 2640  
AL 2660  
AL 3260  
AL 3270  
AL 3580

Terminale  
**T ...5.17.G**

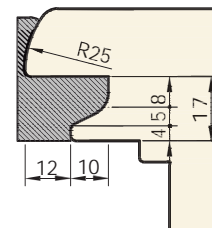

AL 2610  
AL 2630  
AL 2640  
AL 2660  
AL 3260  
AL 3580

Terminale  
**T ...9.17.G**

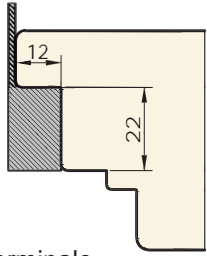

Terminale  
T ...5.22.12

AL 2410  
AL 2610  
AL 2630  
AL 2640  
AL 2660  
AL 3260  
AL 3580

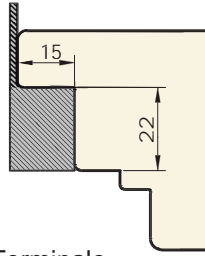

Terminale  
T ...5.22.15

AL 2410  
AL 2610  
AL 2630  
AL 2640  
AL 2660  
AL 3260  
AL 3580

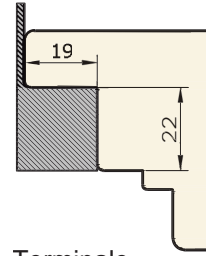

Terminale  
T ...5.22.19

AL 2410  
AL 2610  
AL 2630  
AL 2640  
AL 2660  
AL 3260  
AL 3580

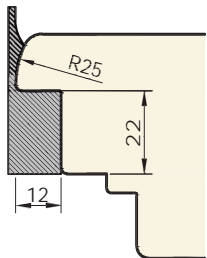

Terminale  
T ...9.22.12

AL 2610  
AL 2630  
AL 2640  
AL 2660  
AL 3260  
AL 3580

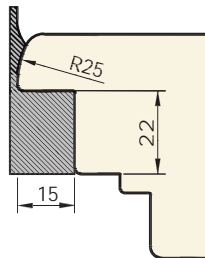

Terminale  
T ...9.22.15

AL 2610  
AL 2630  
AL 2640  
AL 2660  
AL 3260  
AL 3580

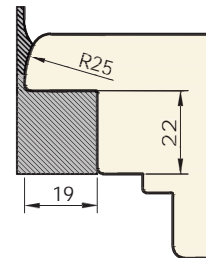

Terminale  
T ...9.22.19

AL 2610  
AL 2630  
AL 2640  
AL 2660  
AL 3260  
AL 3580

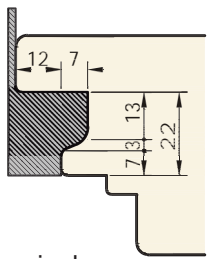

Terminale  
T ...5.22G12

AL 2410  
AL 2610  
AL 2630  
AL 2640  
AL 2660  
AL 3260  
AL 3580

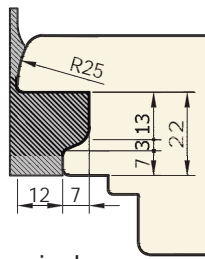

Terminale  
T ...9.22G12

AL 2610  
AL 2630  
AL 2640  
AL 2660  
AL 3260  
AL 3580

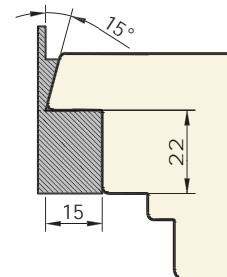

Terminale  
T ...7.22.15

AL 2610  
AL 2630  
AL 3260  
AL 3580

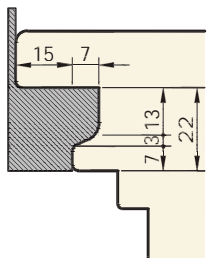

Terminale  
T ...5.22G15

AL 2410  
AL 2610  
AL 2630  
AL 2640  
AL 2660  
AL 3260  
AL 3580

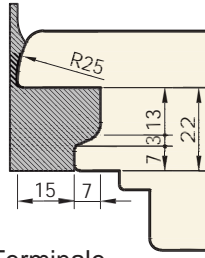

Terminale  
T ...9.22G15

AL 2610  
AL 2630  
AL 2640  
AL 2660  
AL 3260  
AL 3580