

103814 - Guarnitura maniglione HS 12 maniglia+conchiglia est. corta 13 mm perno interno 10 con viti M6x110 quadro 10x93 spessore profilo da 108 mm argento F1

Disegni tecnici

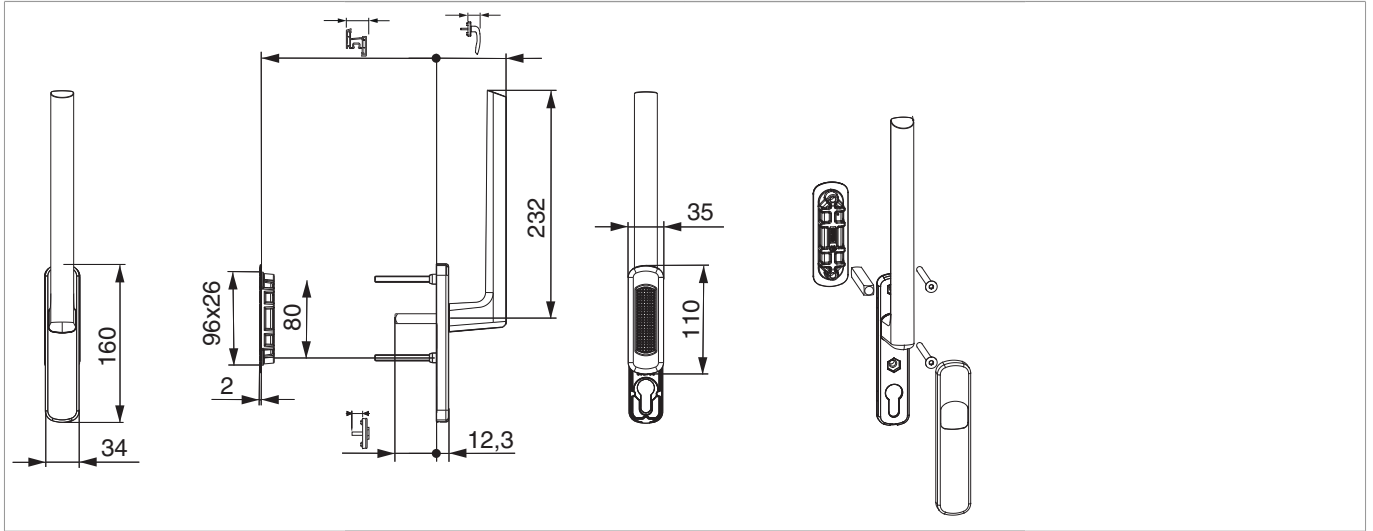









									
argento	F1	72	108	93	10	10	anodizzato	1	103814

Immagine prodotto





Schema foro e fresata

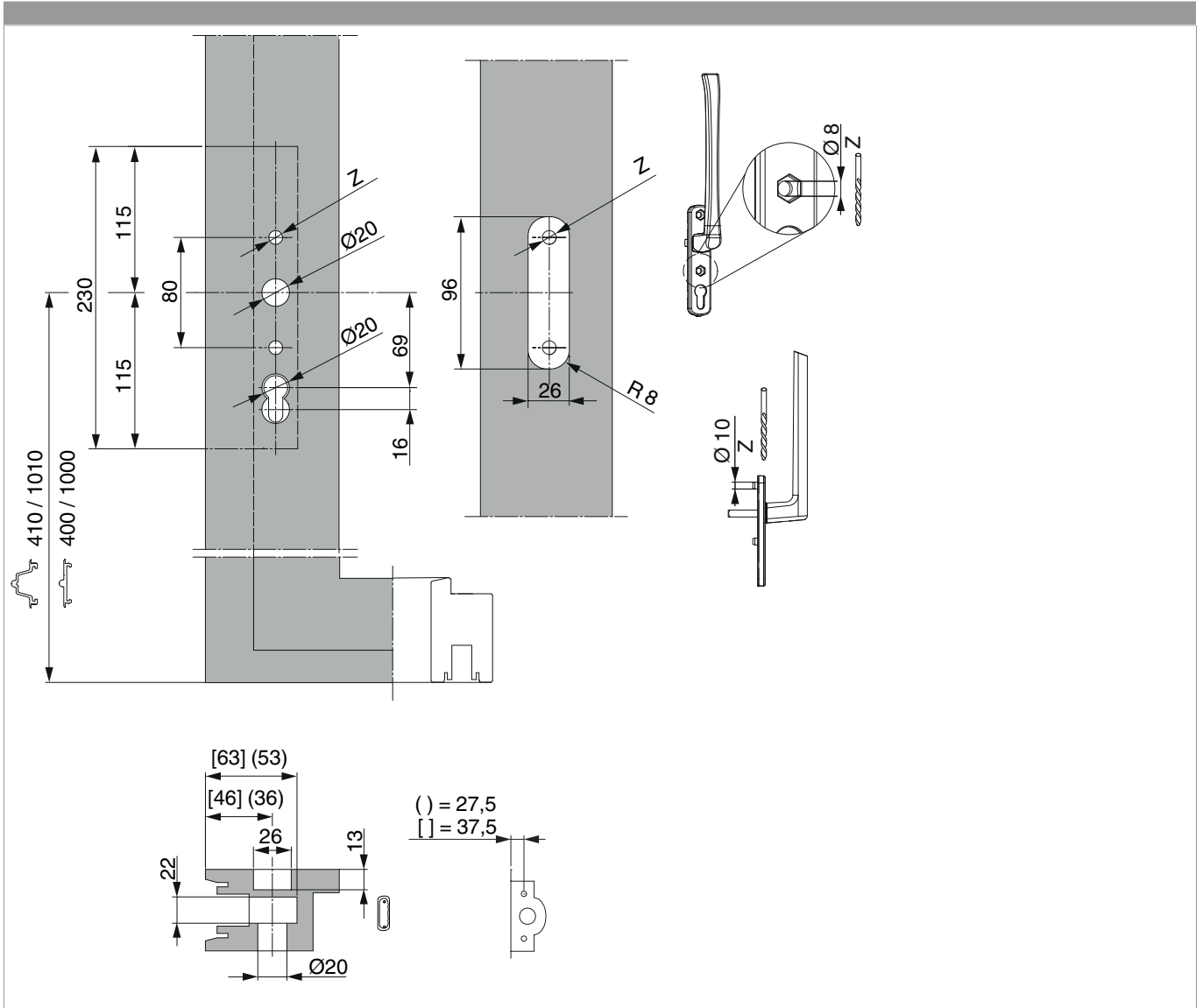



Montaggio

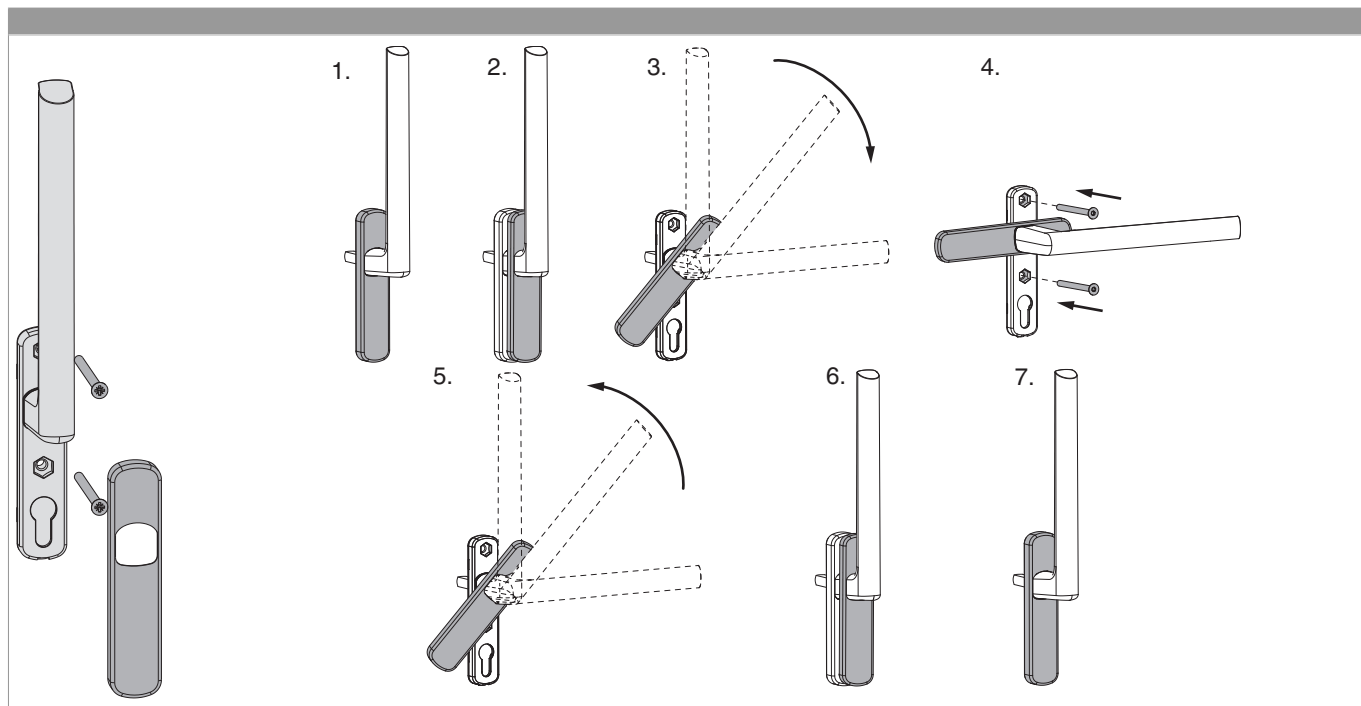



Quote

