

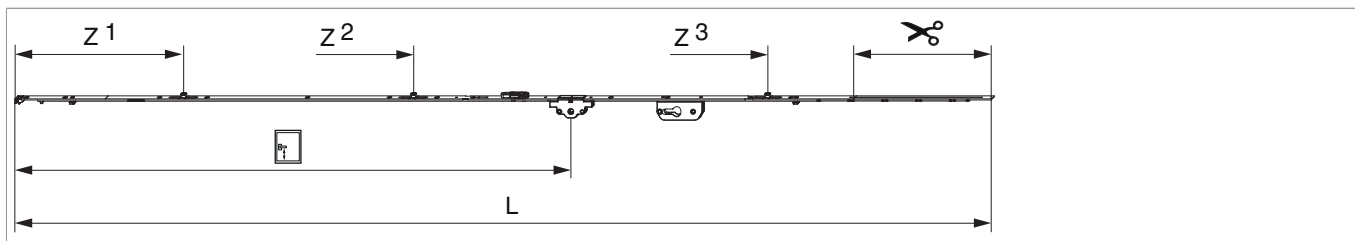

205633 - Cremonese Multi Matic 2200 E45 fix bloccabile con cilindro con 3 funghi HBB 1.951-2.200 HM1.050 argento

Disegni tecnici



							L		N°
argento	2200	45	1.050	1.951 - 2.200	260,5	1	2.096,5	10	205633

Tabella posizionamento viti

N°		1	2	3	4	5	6	7	8	9	10	11	12	13	14
205633	12	18,5	91,5	270	360	550	705	795	863,5	1.124	1.388	1.465	1.729		

Tabella punti di chiusura

N°		Z1	Z2	Z3	Z4
205633	3	315	750	1.420	

Quote della scatola cremonese

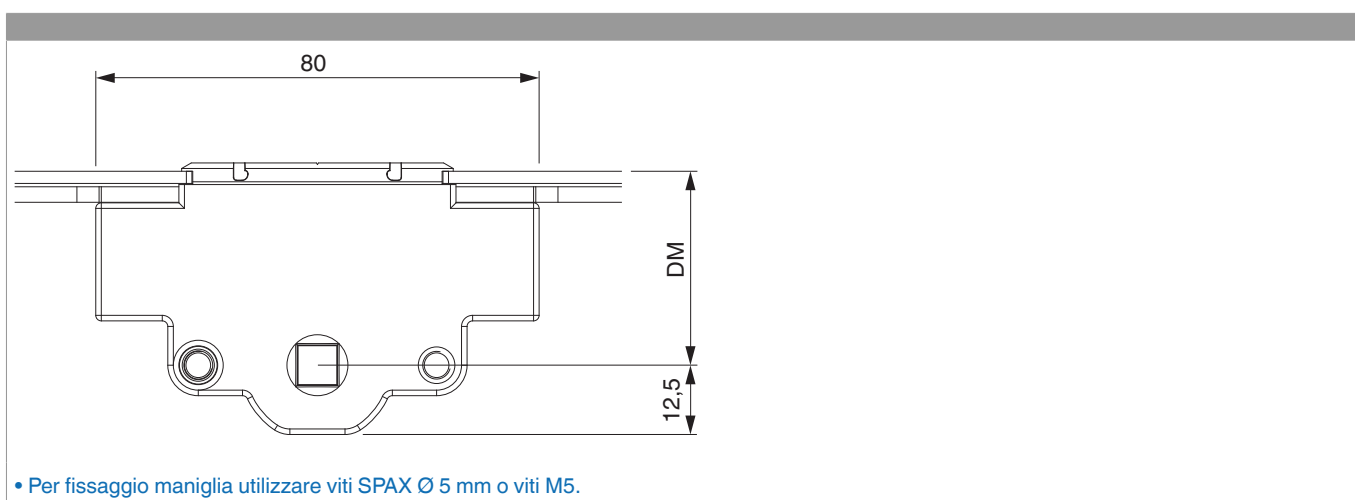



205633 - Cremonese Multi Matic 2200 E45 fix bloccabile
con cilindro con 3 funghi HBB 1.951-2.200 HM1.050
argento

Quote scatola serratura

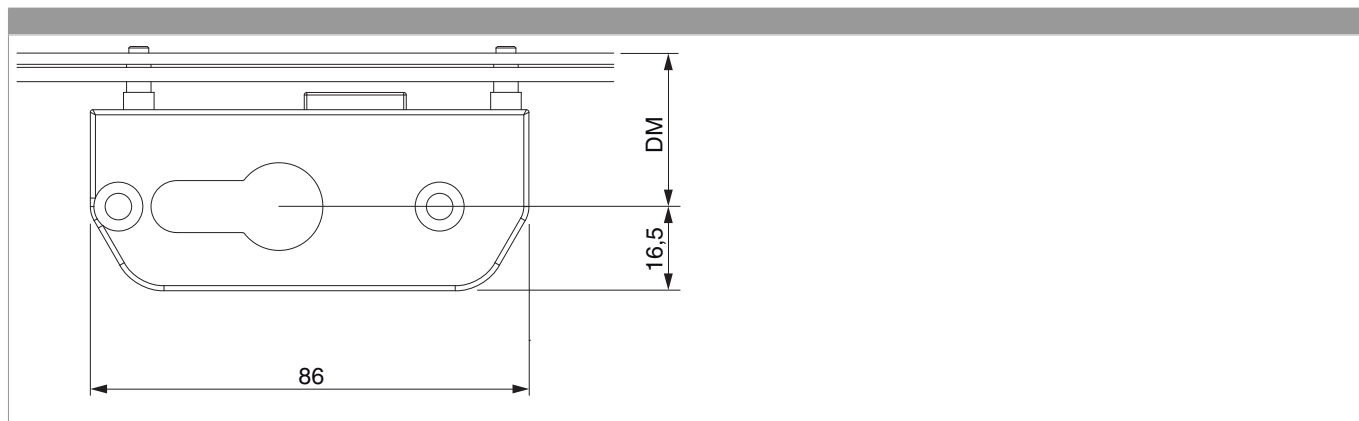

Schema di foratura

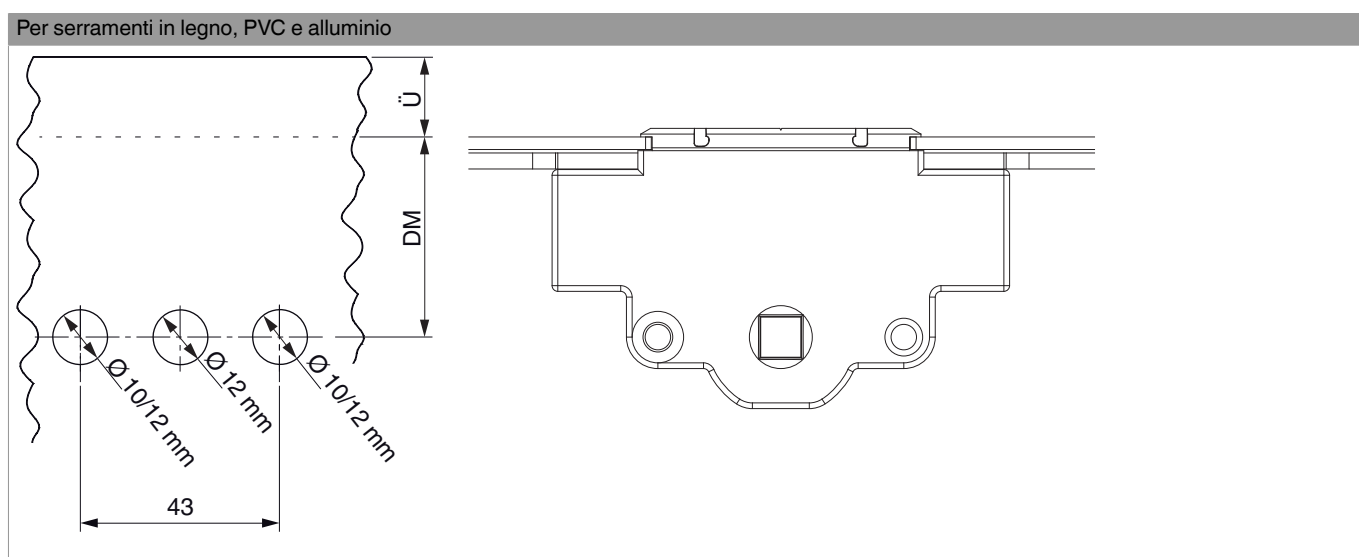



205633 - Cremonese Multi Matic 2200 E45 fix bloccabile
con cilindro con 3 funghi HBB 1.951-2.200 HM1.050
argento

Schema foro per scatola serratura

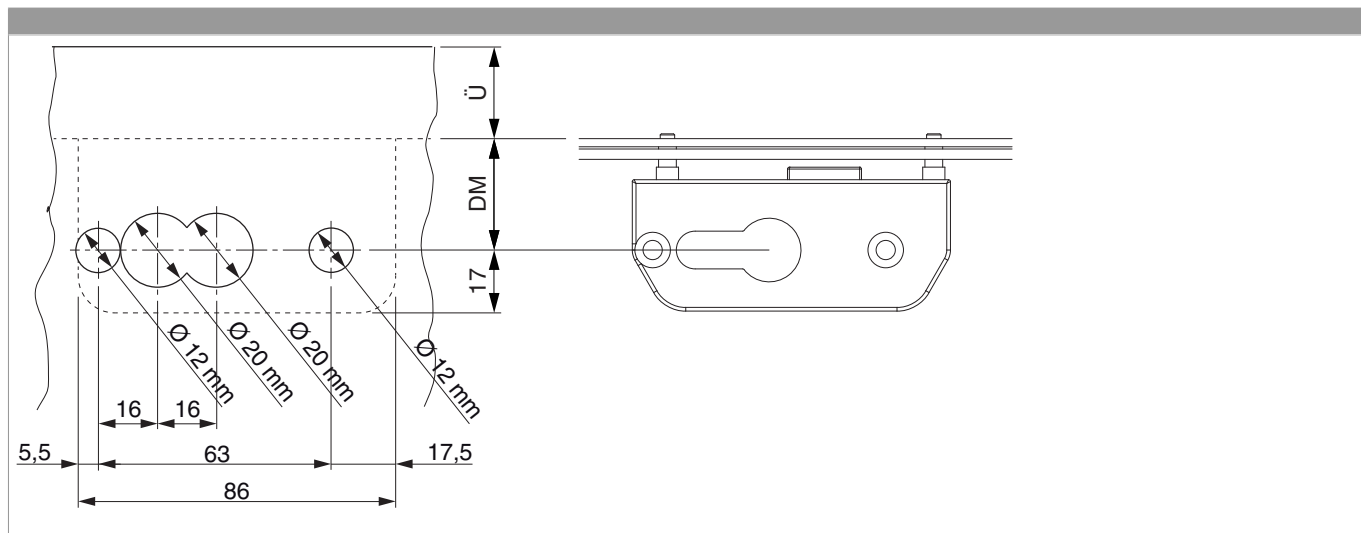



205633 - Cremonese Multi Matic 2200 E45 fix bloccabile
con cilindro con 3 funghi HBB 1.951-2.200 HM1.050
argento

Posizionamento scontri alza anta

Scontro alza-anta A4 / senza scrocco porta

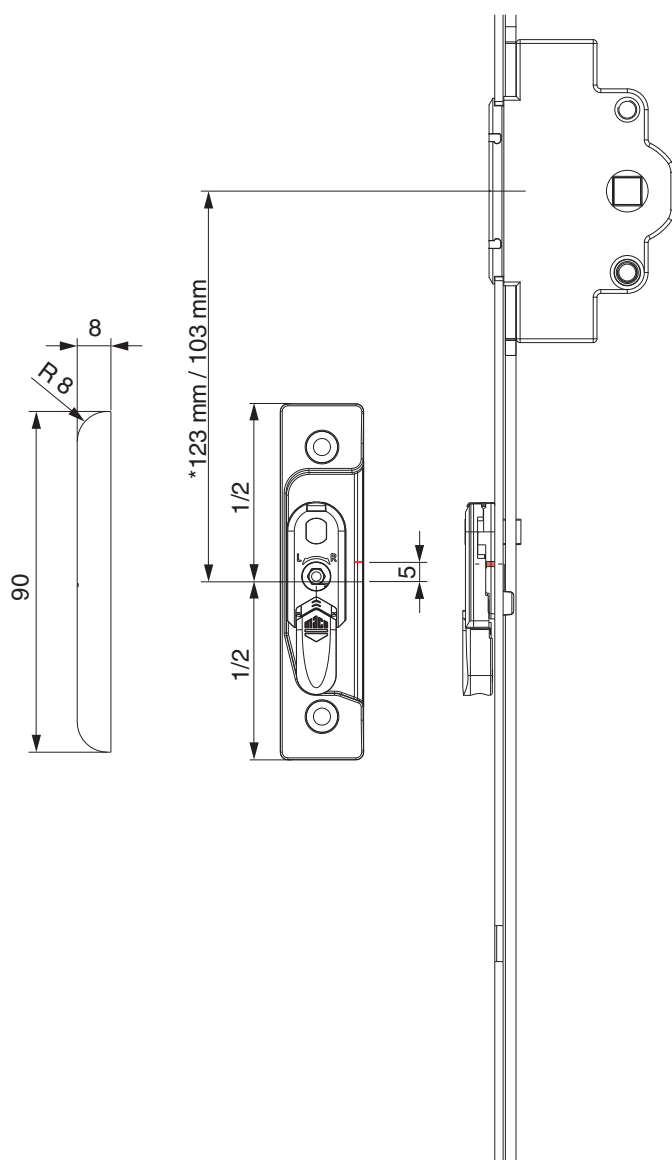

* con cremonesi grandezza 660



205633 - Cremonese Multi Matic 2200 E45 fix bloccabile
con cilindro con 3 funghi HBB 1.951-2.200 HM1.050
argento

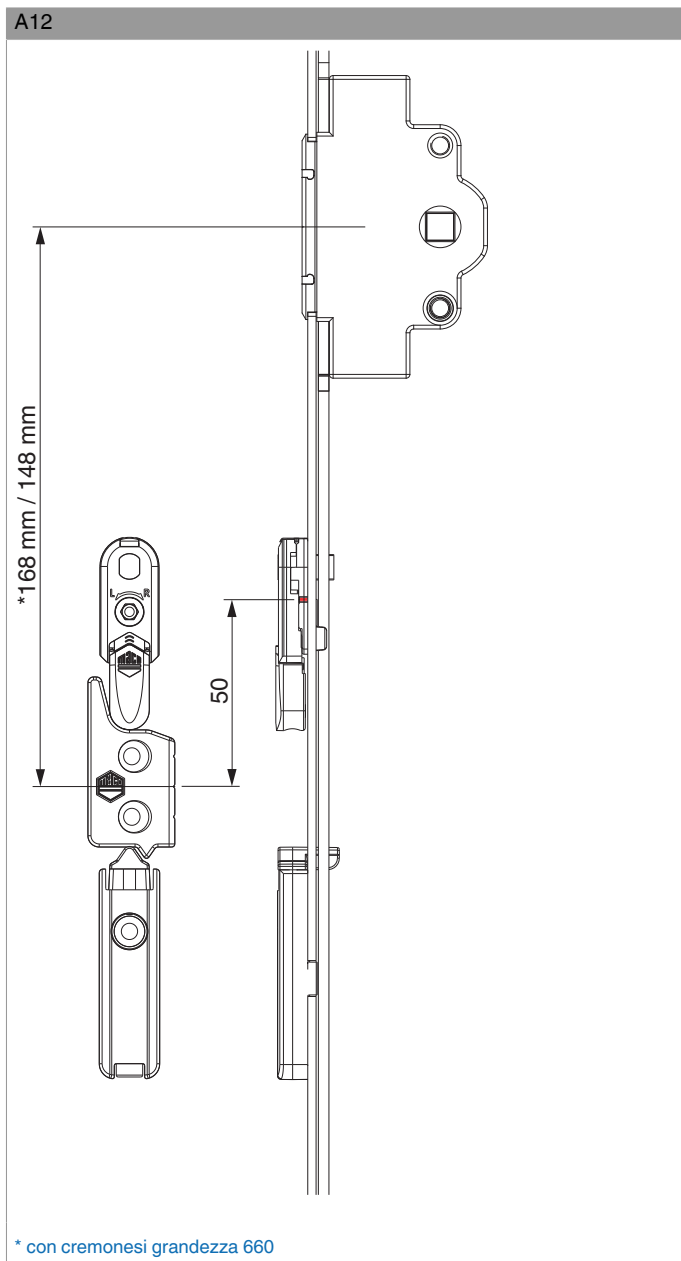



205633 - Cremonese Multi Matic 2200 E45 fix bloccabile con cilindro con 3 funghi HBB 1.951-2.200 HM1.050 argento

Schema di tranciatura

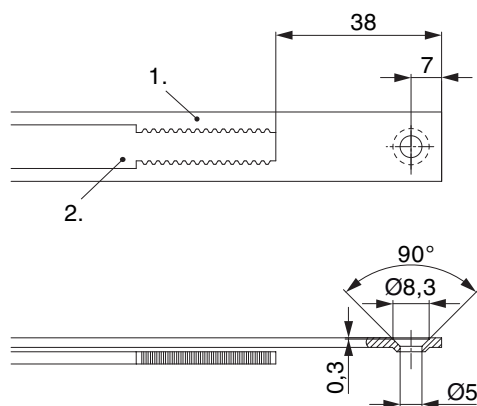

• Consigliamo di trattare il taglio dei componenti TRICOAT-PLUS con la vernice di ritocco TRICOAT-PLUS (cod. 358440).

1. Frontale
2. Asta mobile

Oscillazione e regolazione in altezza dell'alza anta

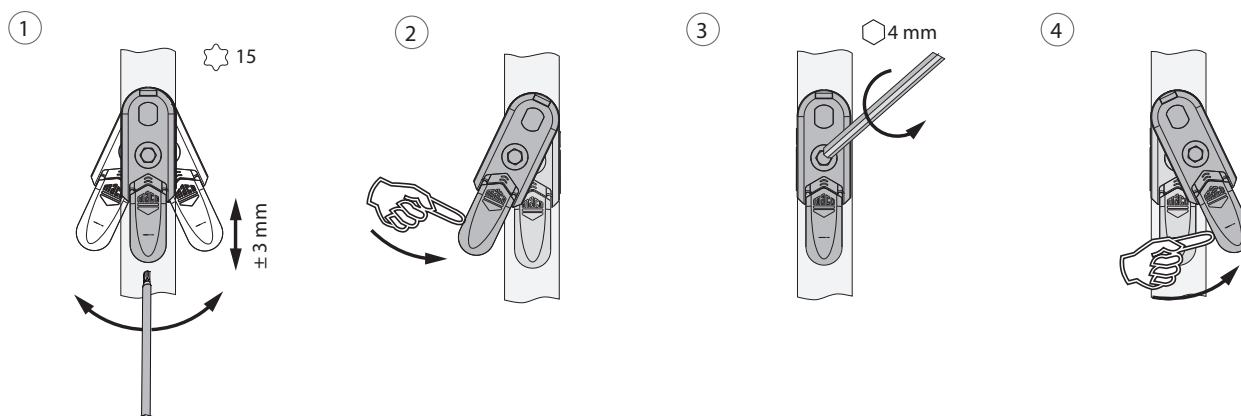

1. Oscillazione e regolazione in altezza dell'alza anta
2. Azzeramento dell'alza anta
3. Fissaggi centrali del dispositivo alza anta.
4. Orientare il dispositivo alza anta.



205633 - Cremonese Multi Matic 2200 E45 fix bloccabile
con cilindro con 3 funghi HBB 1.951-2.200 HM1.050
argento

Collegamento a clips

Agganciare collegamenta a clips

①

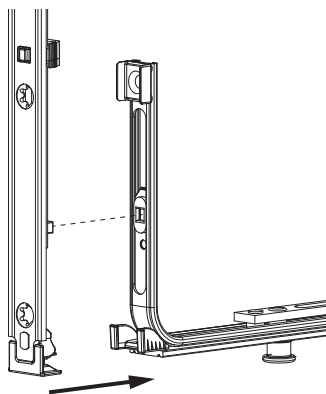

②

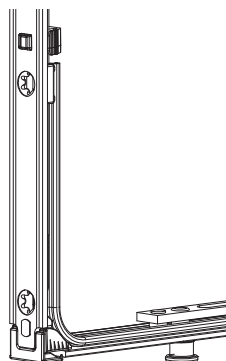

Sganciare collegamento clips

①

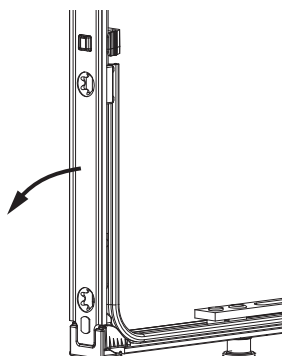

②

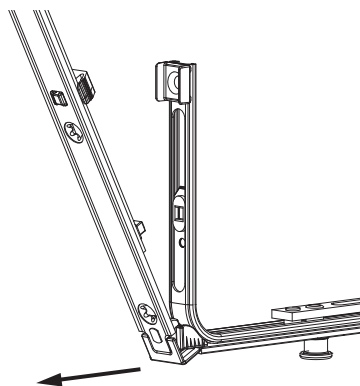

③

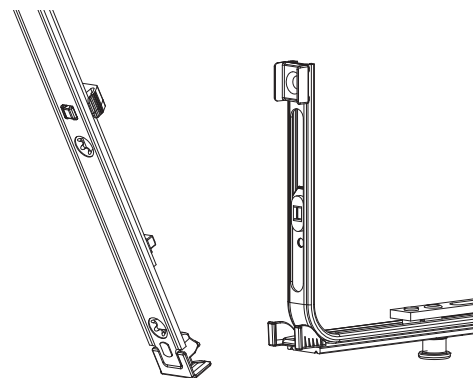



205633 - Cremonese Multi Matic 2200 E45 fix bloccabile
con cilindro con 3 funghi HBB 1.951-2.200 HM1.050
argento

Collegamento scarpetta dentata

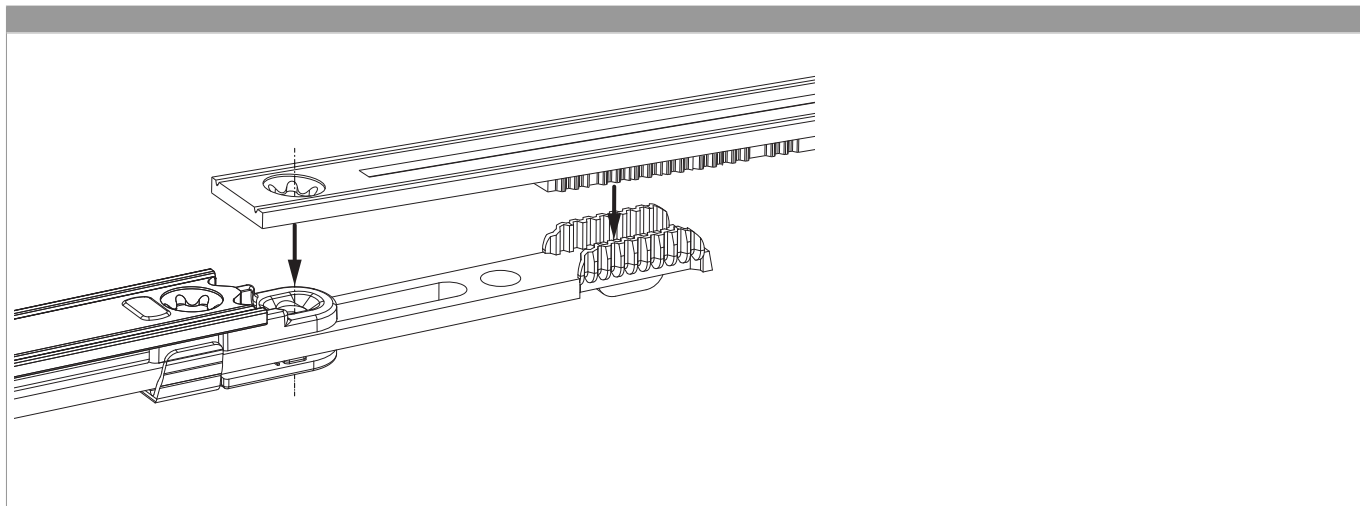



205633 - Cremonese Multi Matic 2200 E45 fix bloccabile
con cilindro con 3 funghi HBB 1.951-2.200 HM1.050
argento

Cremonese con serratura - preparazione della finestra

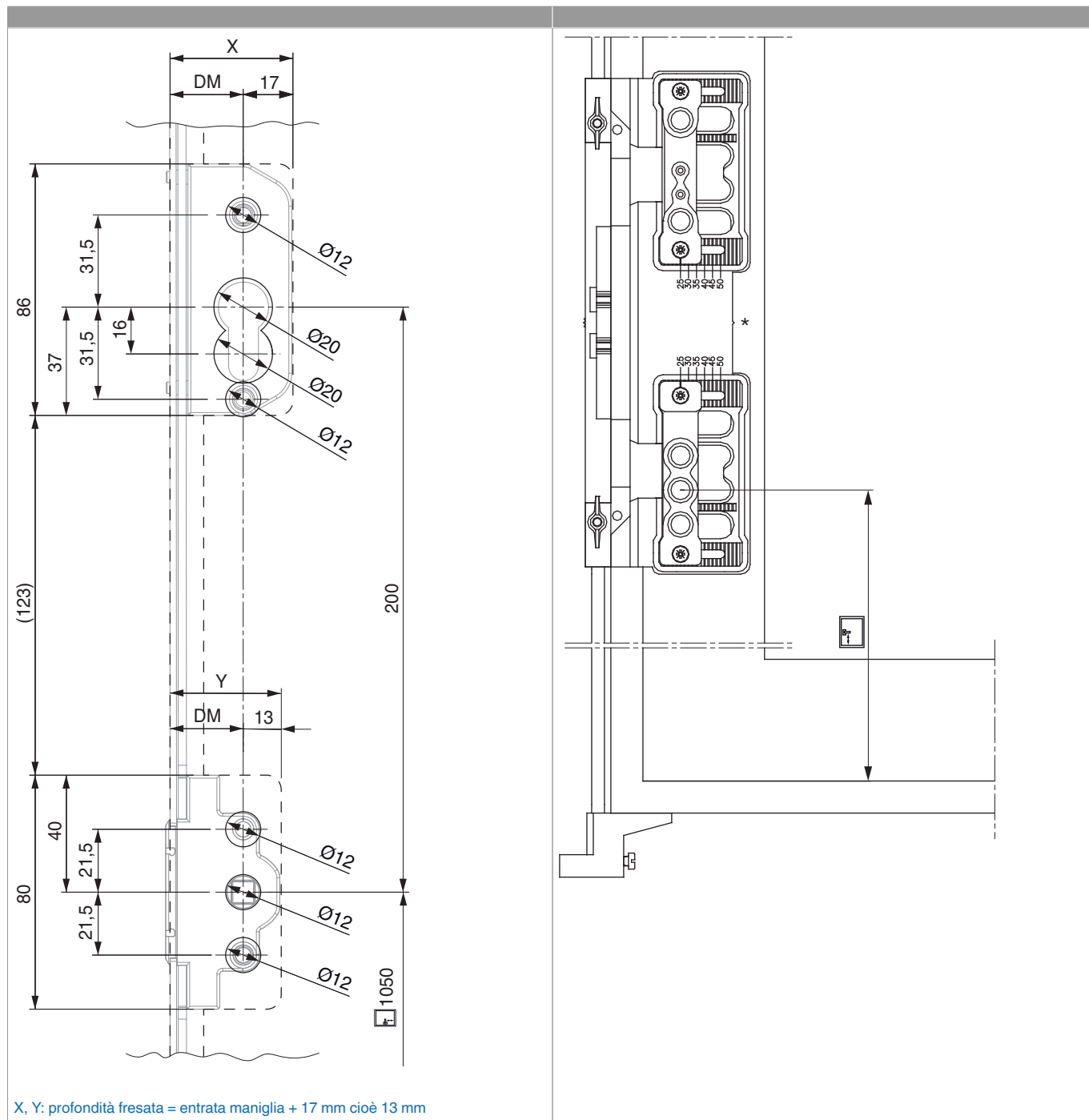



205633 - Cremonese Multi Matic 2200 E45 fix bloccabile
con cilindro con 3 funghi HBB 1.951-2.200 HM1.050
argento

Regolazione pressione

