

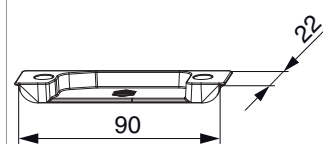

## 357676 - Scontro alza anta MultiMatic per A4 scost. 13 mm sinistro argento

### Disegni tecnici



				L	B	H		Nº
argento	Scontro alza anta MultiMatic per A4 scost. 13 mm		sinistro	90	22	8	100	357676 <sup>1)</sup>

<sup>1)</sup> Su elemento destro usare scontro sinistro e viceversa

### Sezioni profilo

A4 scost.13 - 1 anta

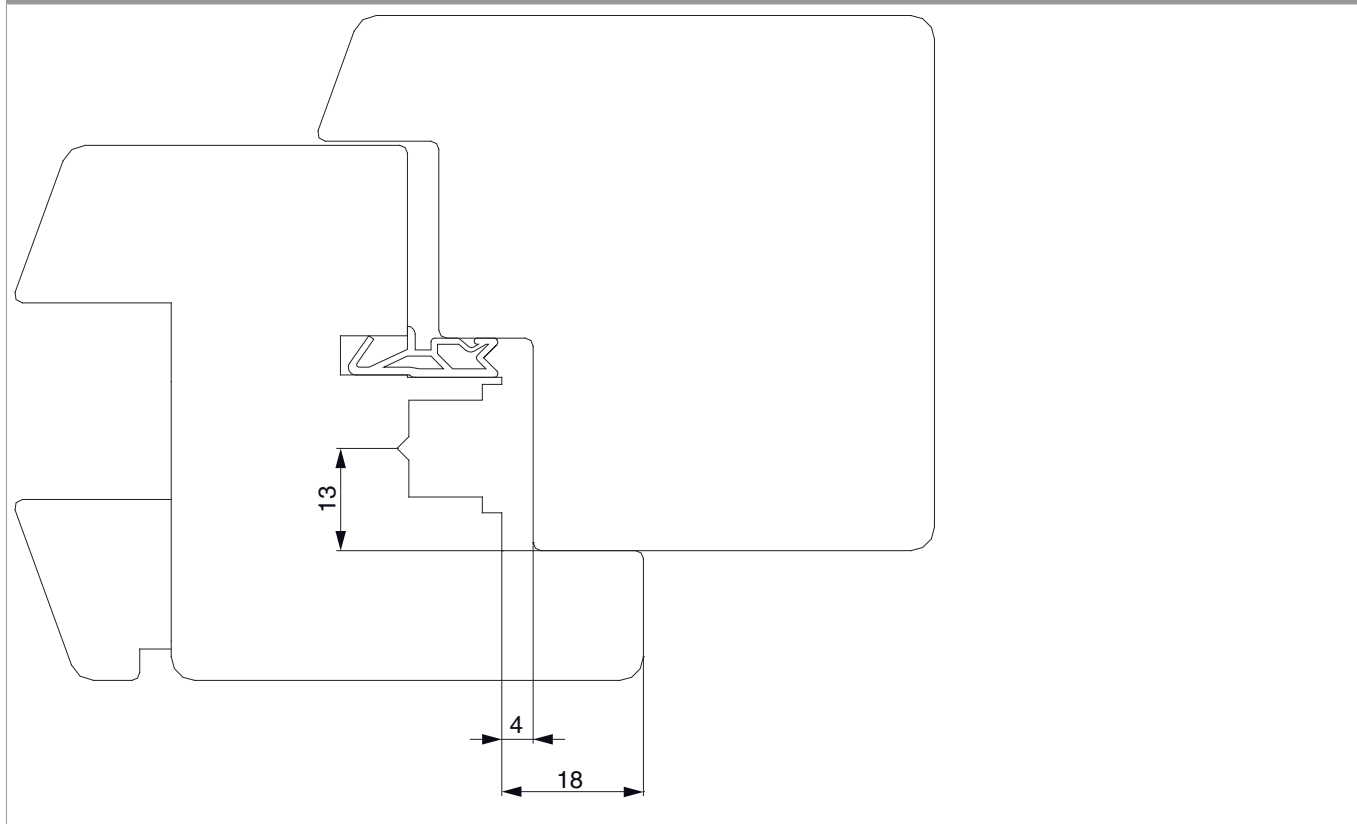



A4 scost.13 - 2 ante

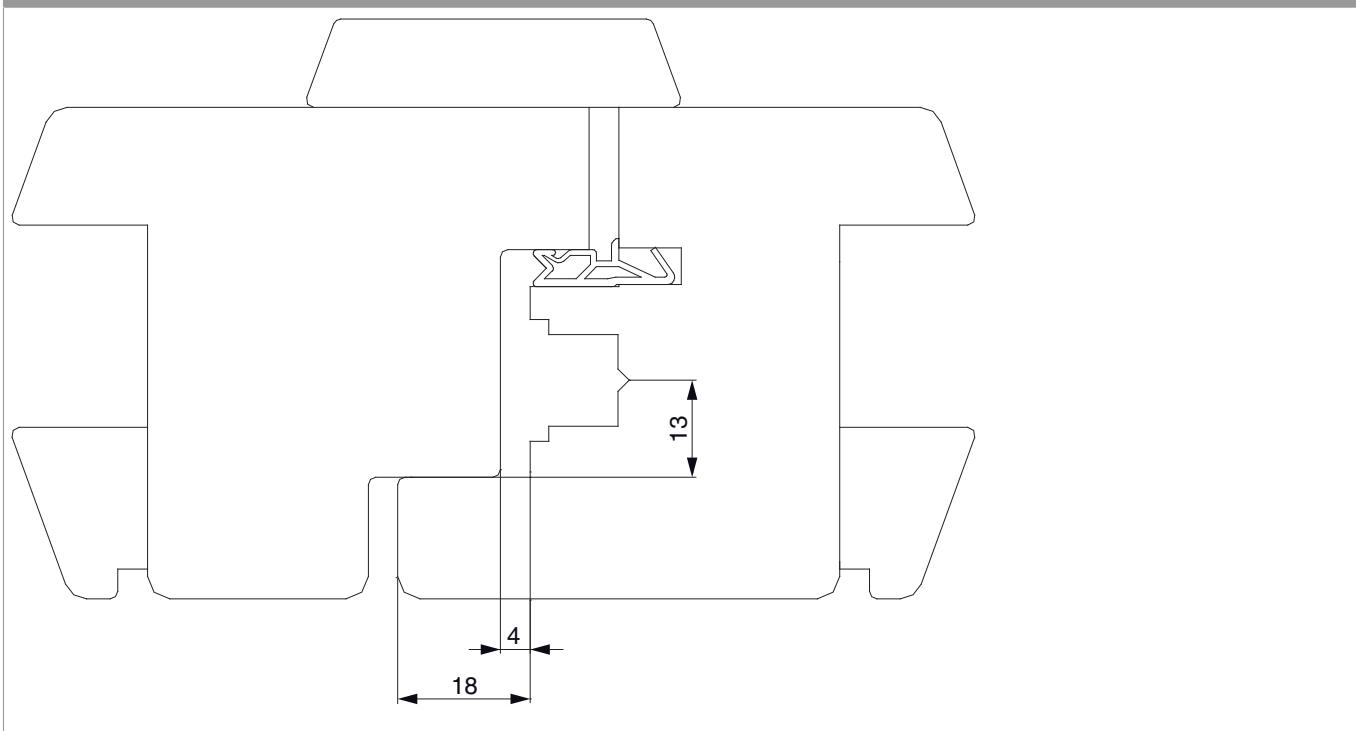

## Posizionamento degli scontri

Scontro alza-anta A4 / senza scrocco porta

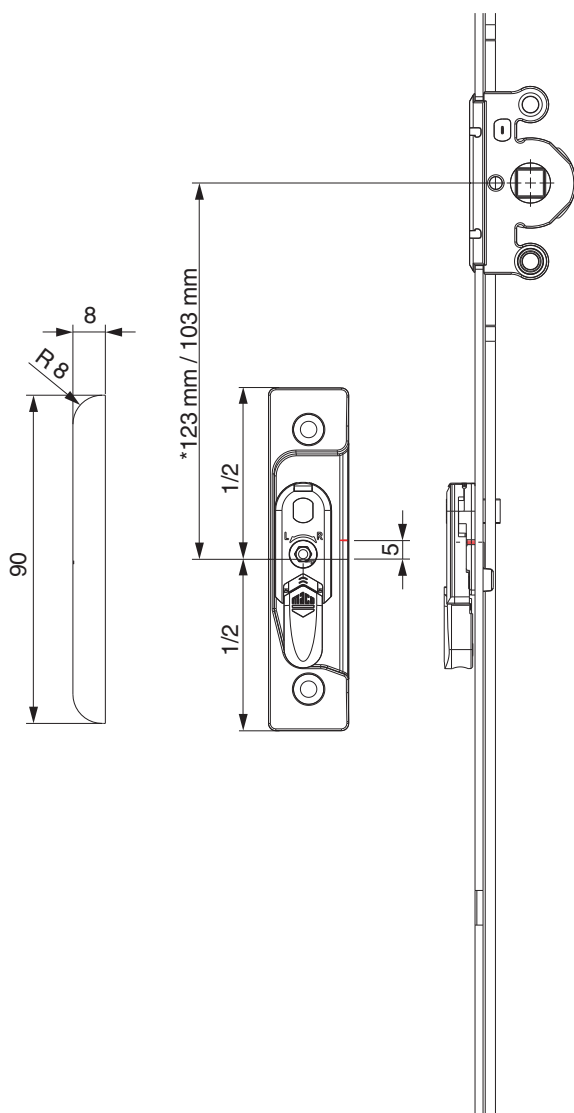

\* con cremonesi grandezza 660



## Fresata

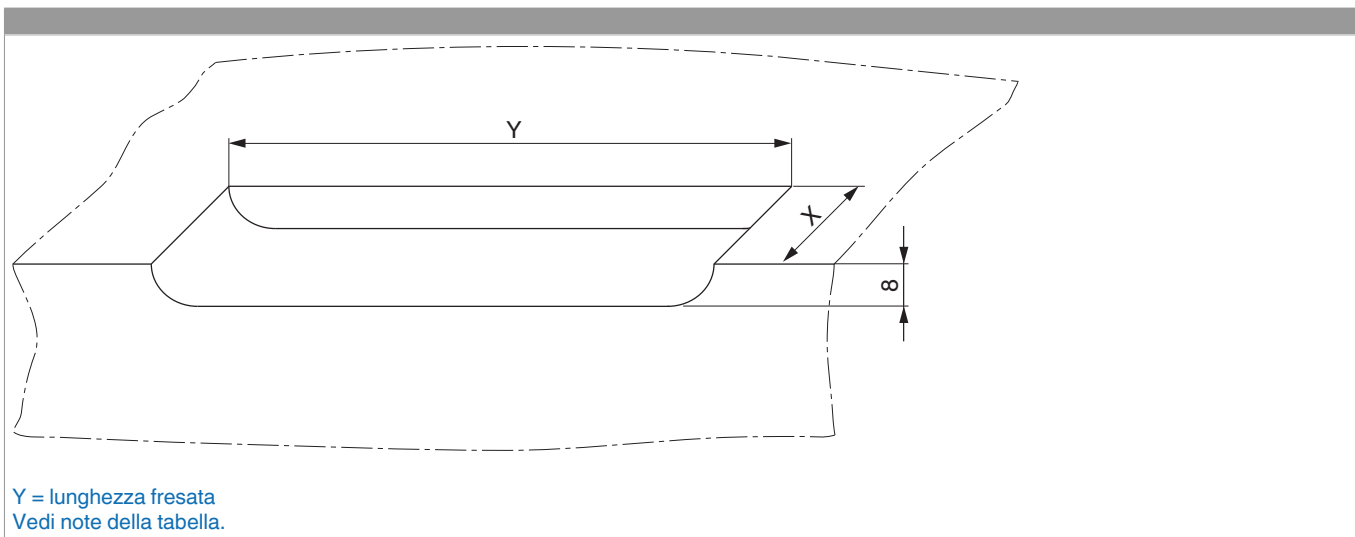

Y = lunghezza fresata  
Vedi note della tabella.

Scostamento	X
scostamento 9 mm	18 mm
scost.13	22 mm