

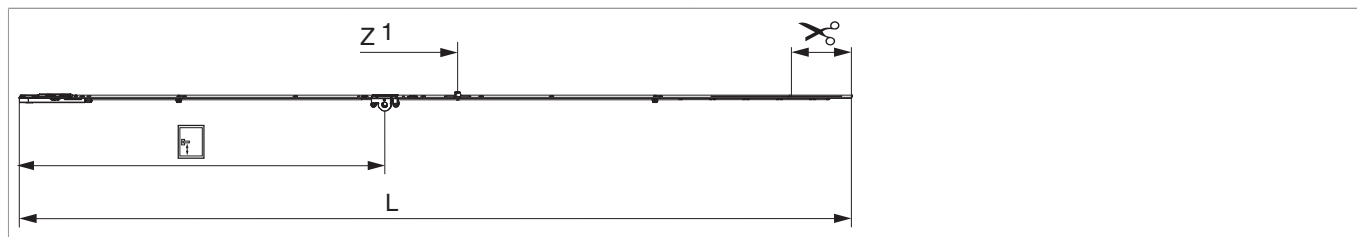

212004 - Cremonese ad inversione Multi Matic 1700 E15 con 1 nottolino HBB 1.591-1.700 HM700 argento

Disegni tecnici



		L						N°
argento	1700	1.596,5	15	700	1.591 - 1.700	260,5	10	212004

Tabella posizionamento viti

N°		1	2	3	4	5	6	7	8	9	10	11	12	13
212004	8	28	119,5	315	528,5	774	885	1.020	1.229					

Tabella punti di chiusura

N°		Z1	Z2	Z3
212004	1	840		

Dime

			N°
Dima forature per fori martellina MM	per punta 3mm	1	203861
Dima forature per fori martellina MM	per punta D=3 mm e D=12 mm	1	203862

Quote della scatola cremonese



- Larghezza fresata per scatola cremonese 12 mm
- Per fissaggio maniglia utilizzare viti SPAX Ø 5 mm o viti M5.

Schema di foratura

Per serramenti in legno

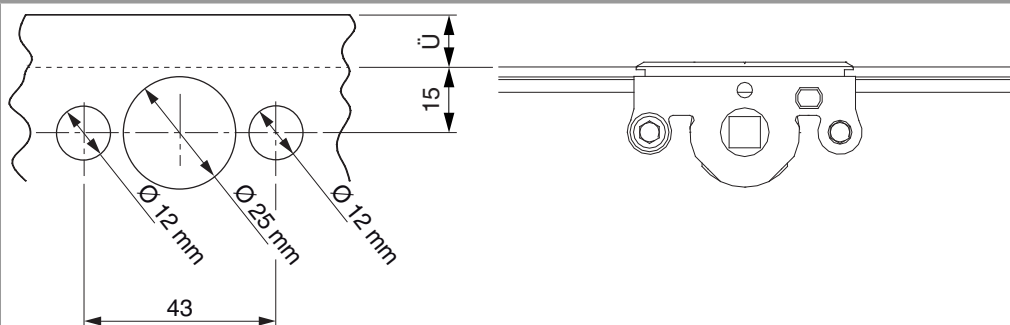

Per serramenti in PVC e alluminio

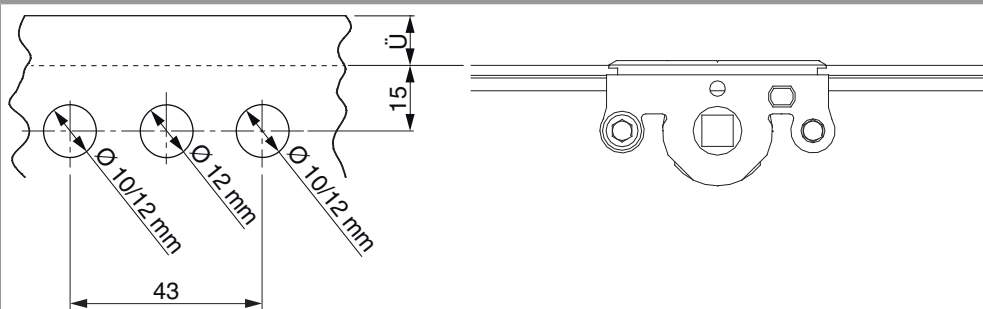

Regolazione uscita puntale (a scelta 11 o 14 mm)

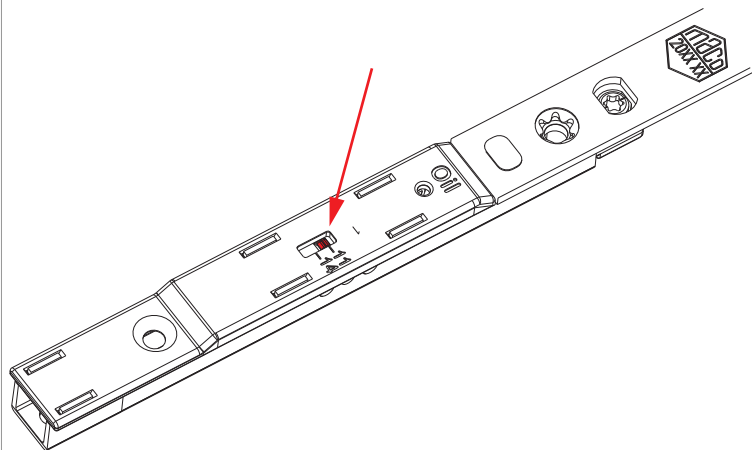

Impostazione di base uscita puntale 11 mm

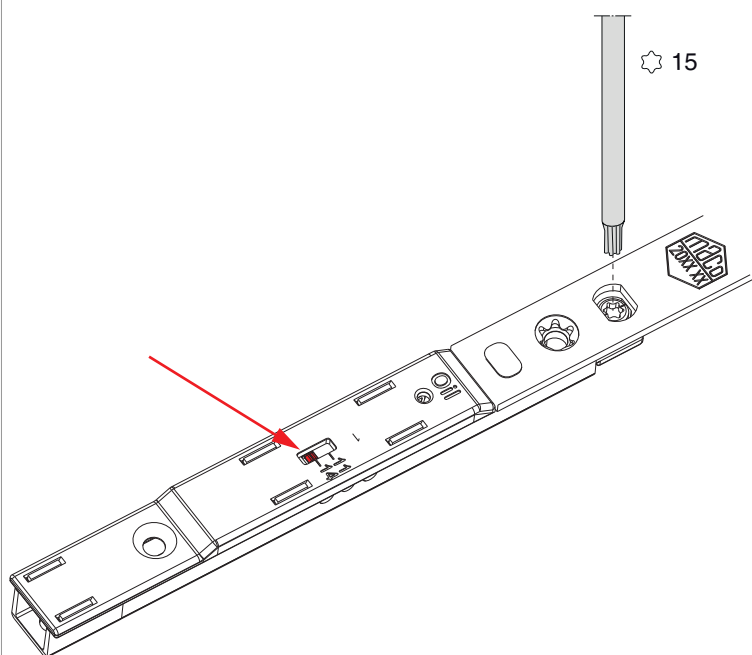

Regolazione del perno eccentrico
Uscita puntale 14 mm

Schema di tranciatura

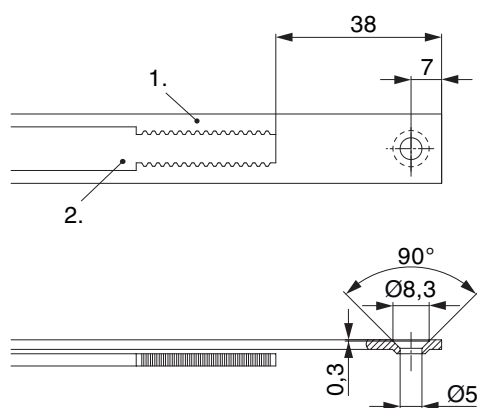

- Consigliamo di trattare il taglio dei componenti TRICOAT-PLUS con la vernice di ritocco TRICOAT-PLUS (cod. 358440).

- 1. Frontale
- 2. Asta mobile

Collegamento scarpetta dentata

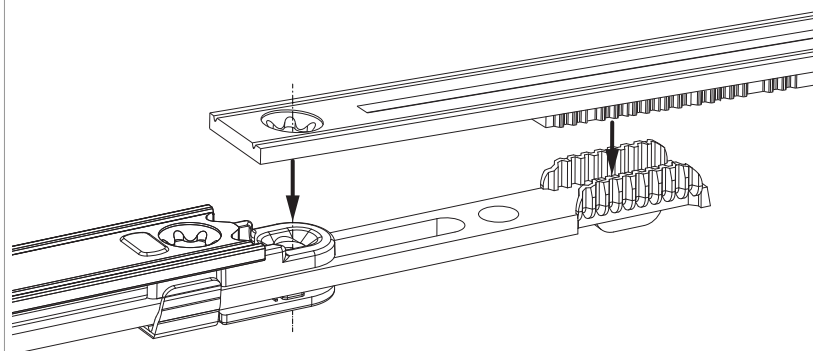

Regolazione pressione

Fungo e nottolino

